

ST ANTHONY'S SCHOOL

Newsletter



Autumn 2024

Dear Parents and Carers

Welcome to our first newsletter for this academic year, where we have had the opportunity to welcome 35 new pupils to the school. It has been an incredibly busy start to the year with lots of activities and visits as well as all the hard work pupils have been doing in class. Hopefully you will have the chance to read about them in the newsletter.

As we approach Christmas, there will be many more events to look forward to which celebrate the festive season. There are a range of exciting activities planned for our pupils and some events that parents/carers and families are invited to attend.

I am pleased to welcome the following new staff to the school, Kayleigh Bone, Robert Boniface, Sarah Clark, Tasmin Diggins, Abigail Goldsmith, Francesca Longdon, Katie Parkin, Caitlyn Roberts, Marketa Stradalova.

A presentation evening was held on 13th November, to celebrate the achievements of the Year 11 pupils who left school last

summer. The event was extremely well attended and it was lovely to see the students. Our results at were extremely good. All of the pupils who left school this year successfully achieved a range of accreditation.

I would like to remind parents and carers that we use email and My Child at School (MCAS) for our communication. At this time of year, there is always the potential that we could have a very cold winter. Please make sure that your email and mobile numbers are up to date. The system is a quick and efficient way of providing parents and carers with up to date information. If you are not receiving communication from us and your details are correct then please check your spam folder. If you are not on the MCAS system, please sign up. The staff in the office can help with this.

St. Anthony's continues to be a very successful and happy school. We could not be as successful without the support

we receive from parents, carers and friends of the school. Please continue to support and work with us. Your support is very much appreciated and valued by the staff and governors.

The last day of term is 20th December and school will be finishing at 2pm.

I would like take this opportunity to wish everyone a very Happy Christmas and New Year.

Ofsted
Outstanding
Provider

Chestnut Classes



Our little group has been exciting. We experienced 'fireworks' by standing under the umbrella and hearing the party poppers go 'pop!'



A special visitor came to us to read us his story "We really want the cake". His name is Simon Philip and he is a children's author.



We have explored 'bread' this term. We had fun using the toaster safely, toasting bread or crumpets with butter and jam.

Chestnut class have enjoyed listening and learning the stories of The Gingerbread Man and Rosie's Walk.

We hope you have a very Merry Christmas and a Happy New Year!





Apple Class

What a busy term we have had in Apple class! We have welcomed many new children and their families to St Anthony's and spent time settling back into the routine of school. We wanted to share with you some of things we have been doing in 'Little Group' (also known as 'Attention Autism').

STAGE 1 - The bucket

This is to gain the children's attention. We have 2 or 3 exciting toys in the bucket which we show the children to engage them in the group time.



STAGE 2 - The attention builder

We present the children with a exciting sequence of events with an amazing finish for them to watch.

STAGE 3 - The interactive game

We invite some of the children to participate in a short game or song. Learning how to take turns and watch each other. Sometimes the adults join in too!



Little Group is all about offering the children an irresistible invitation to learn. All the adults and children in the room share the experience. It's messy, it's fun, and we all laugh and learn so much!



Author visit



Chestnut and Oak had a special visit from Simon Philip, a local author who came to school to read them a story and sign copies of his book to take home. The children engaged really well and had a great time!

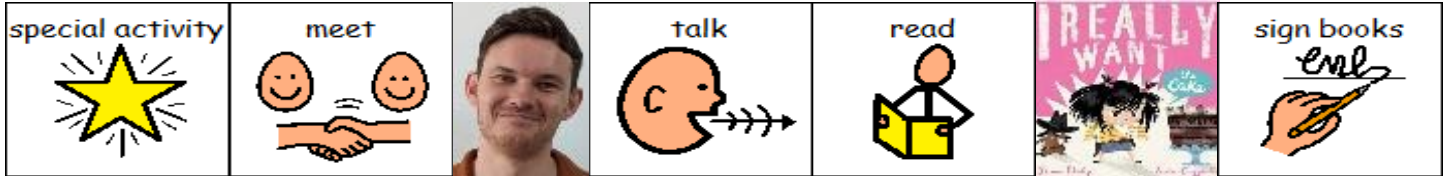

Oak 1 Class

This term our topic has been The Wonder of Me.
We have had fun finding out about our bodies and our senses and
have been reading Funnybones and Dogger.



We have had a lot of fun at Forest School this Term!



We enjoyed a visit from the West Sussex Fire brigade and learnt
some fire safety rules..





Oak 2 Class



Our topic this term has been 'The Wonder of Me'

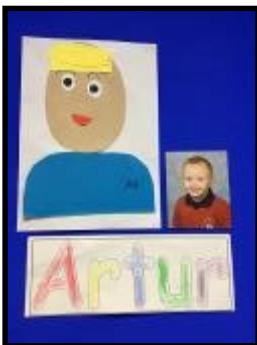

We have been settling into our new classroom and different environments around the school.

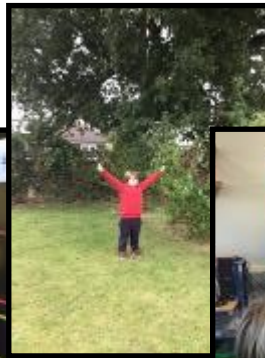



We are developing life skills.

Hawthorn 1

We have enjoyed learning through our topic of the Wonder of Me



We have been learning about ourselves and our bodies.



We have had fun joining in drama sessions and learning through all our senses.



We loved space week.





Hawthorn 2

Our Topic for this term is
The Wonder of Me &
we spent a week learning about Space!



We have been reading:
Dogger, Funnybones and Whatever Next!

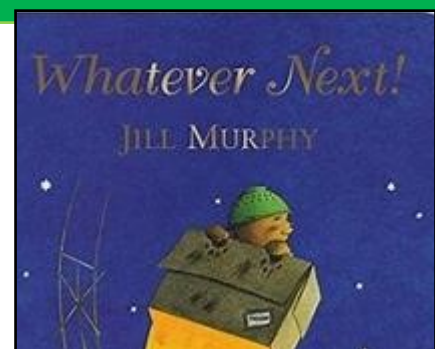
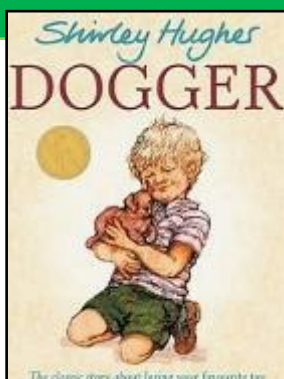

We have used the chromebooks
to create pictures



Fireworks by Reese

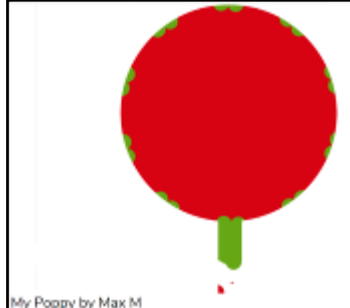

My Poppy by Max M



Princess Ariel by Jayden



Fireworks by Max S



Max's Fireworks

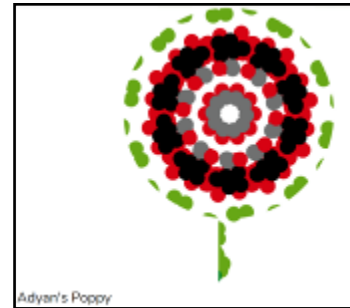

Adyan's Poppy

We enjoyed the visit from
WSFRS



Well-Being Wednesdays



Sycamore



We enjoy DMP and the ball pool as part of our inclusive provision.



The day the fire station came to visit



Autumn celebrations and festivals

We explored Remembrance, Diwali and fireworks.



This term we have been exploring natural and man made materials and begun to sort recycling by material.



We started our term investigating different trees and leaves and exploring the natural world.



Multi-skills in action

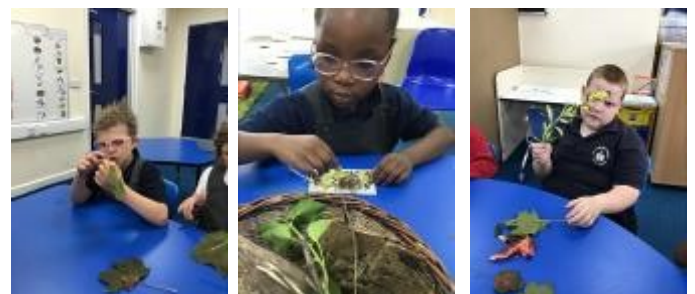

Messy mark making



Beech Class

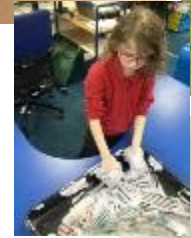

Sensory work times

In our class we learn through a sensory approach

Our topic this term is Ourselves Our World , we made sensory displays over the term to help and support our learning of who we are and where we live.



This term we have started our music lessons with Mr Godon in the music room.

Autumn celebrations and festivals

We learnt more about Diwali, Remembrance Day and the Gunpowder plot.



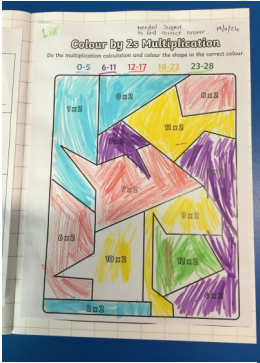

Rowan Class

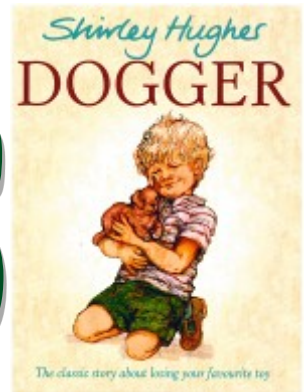

Our topic this term has been the wonder of me, we have been learning about each other and have been exploring jobs that help us. We have also been reading and writing about Funny Bones and Dogger. In numeracy we have been learning about place value, times tables, time and money.

This term Rowan Class have been developing their music skills playing the ukuleles.

Rowan Class have been doing PE and swimming as part of wellbeing Wednesdays. They have been playing team games and developing their swimming skills.



Rowan Class enjoyed spending time in the snow!

Rowan Class learned about Bonfire night and Guy Fawkes, they explored what this event is about and why it is an important event.



Yew Class Autumn 2024

Our learning has been through our All about Me topic, where we have explored parts of our body, feelings and jobs that help us.

We have enjoyed Fire-fighters visit where the focus has been about keeping safe.

We also have been learning about recycling.



We also have explored and learned about Picasso and Kandinsky and their artwork that focuses on self-portraits and mixing colours.

Space week was one of our favourite where we have been exploring solar system and planets.



Year 5 has had great fun visiting Tuppenny Barn. Where we have explored how food is grown and tried new one. We've also gathered windfall apples in the orchard and made apple juice.



We have been celebrating special days.



Bella's Adventures



Bella enjoying her walks at the beach and the woods, playing in the leaves.



Bella enjoying her visit to Forest School.

Bella was excited to be an Aunty, helping with the nursery and waiting patiently and finally baby Maeva arrived.



Happy Christmas to you all and hope you have a lovely time.

Monty's First Term

It has been lovely to welcome Monty to St Anthony's to work alongside Bella to support our children in school.



Monty visiting
Yew Class



Monty has been busy this term completing his training with the Dog Mentor Programme, helping the children learn how to walk a dog safely, visiting classes across the school with Miss Ball, Mrs Davies and Miss Allemand as well as working with Miss Jewson in the pastoral office.



Monty on the field at
the end of the day



Monty's first snow
experience

He is having a great time getting to know the school, staff and pupils.



Monty completing his
Dog Mentor Training

SCIENCE

Our Year 11 pupils, participated in the Blaze course delivered by the West Sussex Fire and Rescue service, Bognor Regis Fire Station, Targeted Education team during the beginning of the Autumn term. The course was focused on developing the pupils' personal resilience skills and other areas such as physical health, positive wellbeing, healthy relationship, and aspirations (careers). The pupils enjoyed every aspect of the course, including their passing-out parade that was attended by parents and local dignitaries.



Year 10 pupils started the Autumn term with an introduction to their qualifications.



They started with Electrical Circuits, which is a three Credit Unit.

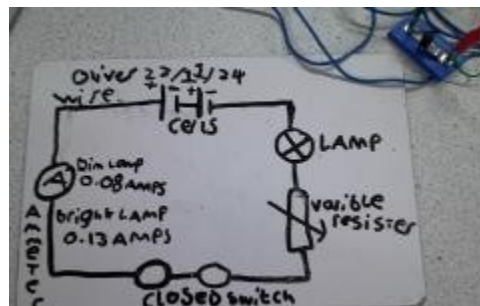
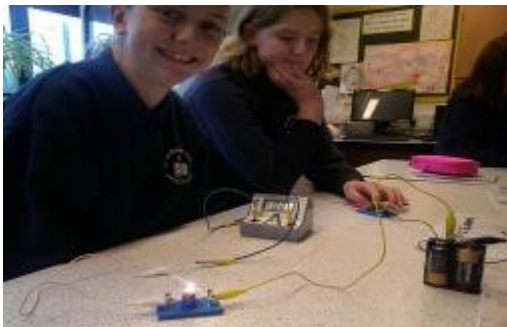

Year 9 pupils are learning about Microscopy and relating this to Cells and Principles of Organization.

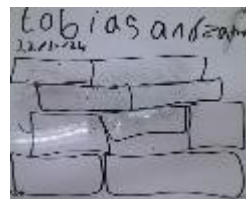

SCIENCE

Year 8 pupils are learning about Biodiversity and Classification of Organisms using primary and secondary data. This is then progressed to Interdependence of organisms.



Year 7 pupils started the autumn term learning about jobs linked to the study of science and the three main branches of science. This allow the pupils to have role play on different jobs, explore simple lab apparatus within a practical context, including the Bunsen burner! Well done Year 7!



ENGLISH

Year 7

We have been working on our Poetry topic. The pupils have looked at a variety of poems, including list poems, shape poems and Haikus. They have listened to poems by Michael Rosen and enjoyed creating alliteration and sharing some silly sentences.

What am I?

Haiku Poems by

Zach 7L



Oliver 7BK

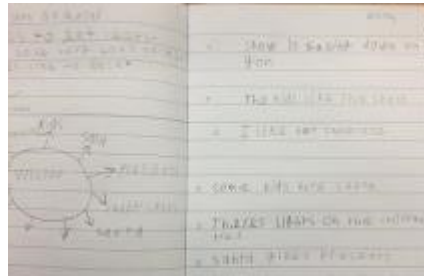

Hope 7L

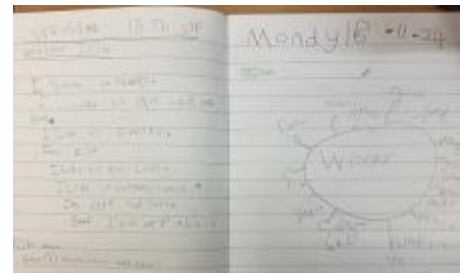

Year 8

We have been looking at the text 'Danny the Champion of the World'. We visited Goodwood Education Centre this term. We walked around the dairy section and then up to Seeley Copse where we listened to some more of the story. The ladies spoke to us about the trees, animals and birds that are native to the area. We also managed to see and hear some Pheasants and had fun flying kites.

Pupils have been completing character descriptions, sequencing activities and storyboards this term.



ENGLISH

This term Year 11s have been creating their own hotel as part of their spoken language assessments. They have researched different hotels, made their own and presented them to each other.

We visited The Goodwood Hotel at the start of the topic. I was very impressed with the questions the pupils asked. They were able to walk through the hotel and were shown the different types of rooms and facilities in the hotel.

Year 10 have been learning about our environment. They have come up with an idea for a product that is made from recyclable materials or would help the environment and presented this to their peers. At the start of the topic we visited Mulberry Marine Experiences in Selsey. The pupils learnt about the marine wildlife on our beaches and actually found 98 egg cases in their 15 minute challenge which included spotted cat shark, skate and two different kinds of ray.



Year 9 have read Kensuke's kingdom. They have looked at character and plot and been learning how to answer questions related to the text. They have done very well to understand some of the complex sections of the story.



HISTORY

The Tudors

Year 8 have been learning about The Tudors. To consolidate their learning in the classroom, Year 8 visited The Mary Rose Museum and had a superb day out. Pupils explored all decks of the museum and took part in a workshop where they learned about what life was like aboard the Mary Rose and the jobs the crew undertook. They enjoyed handling artefacts and hearing individual crew stories. The highlight of the day was the new immersive *Dive the Mary Rose 4D Experience*. We look forward to going again.

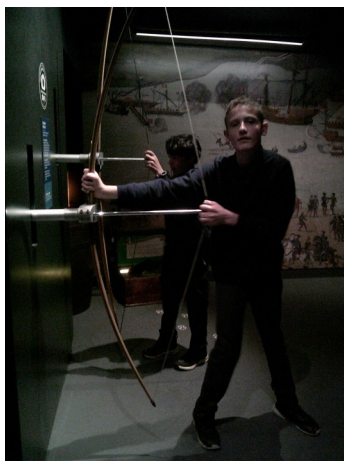

Year 10 The Humanities Entry Pathways group have been learning about Germany between the Wars 1919-1939. They have learned about the signing of the Treaty of Versailles and the impact this was to have on the failure to keep peace in Europe after WWI. Here pupils are using role play to understand what happened during this period in History.



HISTORY

KS3 History

In History Year 7 pupils have been studying the Romans during the Autumn term. They have taken part in various role play activities including a Roman Boot Camp and Rena acting the story of Boudicca Queen of the Iceni.

In History Year 9 pupils have been studying the Trans-Atlantic Slave Trade and the British Empire. They learned about the Trade Triangle, how slaves were captured and the conditions that Slaves endured once transported to America.



HISTORY

The Year 7s have started the year well in History and are keen historians. They have been learning history skills which include understanding timelines and what is historical evidence. This term pupils have visited Fishbourne Roman Palace. Pupils enjoyed exploring the site and seeing the fine mosaics, artefacts and the Palace gardens.



Mosaic Homework. Well done.

Alex 7D

Aastha 7L

MATHS

Key Stage 3

We started the year with some number skills. The big number tiles were very useful for helping us to add and subtract!



We've enjoyed using the peg boards to investigate repeating patterns. After we had created patterns using shape, we used our skills to create number sequences.

Year 9 investigated shape tessellation. They have coloured some fish using repeating patterns and then tessellated them.



Year 7 have talked about what they already know about money. They have been adding coins together and writing the totals. Year 8 have been subtracting decimals and Year 9 have looked at budgeting.

MUSIC



Year 11 Composing exam pieces

Pupils composed on garageband choosing from the genres Dubstep, Electronic, Funk, Hip Hop or House.

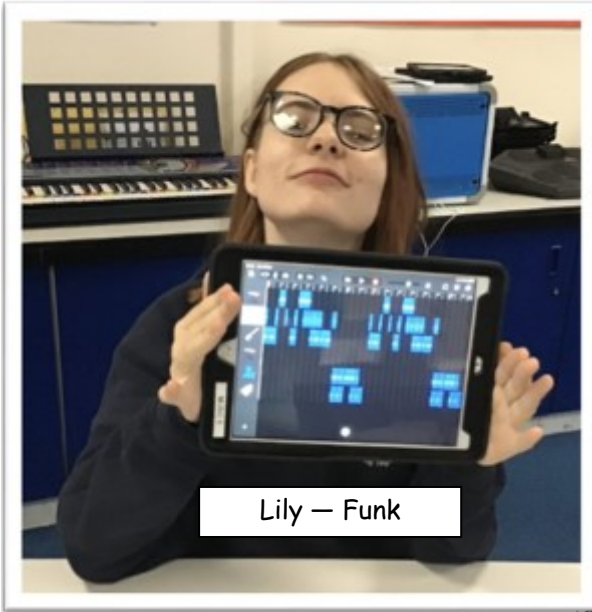

Lily – Funk

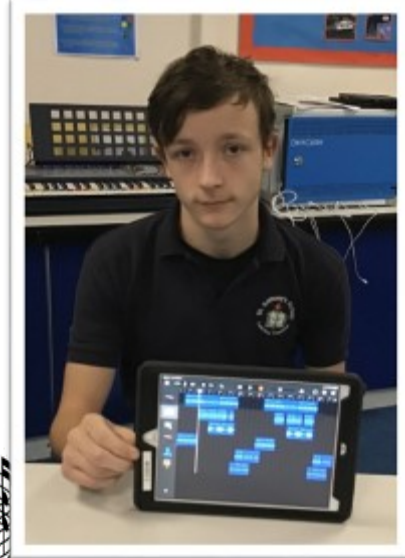

Theo – Dubstep

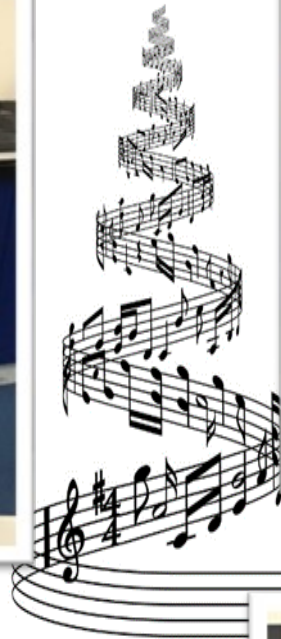

Freddie – House



Bailie – Electronic



MUSIC



Year 10 learning the skills required to perform Solo pieces for their exam.



Amelia
'Yesterday'



Chloe
'Evening Rise'



Ben
'Quibble Gold Island'

My Singing Monsters Quibble Gold Island

Ile de l'or ♩ = 140

mp



Caleb
'I Predict A Riot'



Oliver
'Jolene'



Photos from KS2 and KS3 Music lessons

Alexandra (Beech Class)



Whole class festive play alongs



9C



Toby and Judah (7BK)



8JB

Festive instrumental practise



Brandon (9G)



Zachary (7L)



Rhys & Aashta (7L)



Tallula (9G)

Year 7 instrumental practise



Dylan (7D)



Charlie (7D)



George (7D)



Henry (7D)

FOREST SCHOOL



What a fantastic start to the Autumn term, NO RAIN! (yet). Our Forest schoolers have been very busy indeed.

Since September they have been busy making some fantastic crafts out of the natural materials that we found around the site. One of the Year 10s made this lovely Pudsey for Children in need. There has also been some inventive cooking, with the request to make chicken pie over the camp fire. The pie tasted lovely, but they came up with the idea of putting mashed potatoes on top instead of pastry.

Year 11s planted pumpkins back in the spring. What a result, they had lots to carve. With the biggest pumpkin, they cut a hole on the base and placed it on the fire. We didn't have any candles, it looked great.

Now we are heading into the colder months, we are going to keep the fire going, along with lots of cooking and we have already started thinking about making Christmas crafts.

Mr Clark, Forest School Leader



Careers and YAS

Independent travel training for Year 11 pupils.

In October all Year 11 pupils attended a safe train travel workshop in school and then had the opportunity to travel by train to Littlehampton for lunch.

Whilst out the pupils also learnt about road safety, talking to people that help us in the community and some even took the opportunity to order their own lunch at a café.

This was an invaluable experience for pupils to learn the skills needed to become independent travellers post-16.

This was available through the Southeast Communities Rail Partnership.



FRENCH



This term in French in Year 9, we have been learning about where we live, rooms in the house and places in town. Joshua, who has joined us this September, has gained great confidence in the subject, which is new to him, and was able to lead through the PowerPoint with the rest of his class. George and Dexter, and the rest of 9C, have continued to demonstrate great ability in using the language to respond in class activities.



COMPUTING

Year 7

The Year 7s have had a great start to their time at St Anthony's and over this term have been getting to know our Computing suite and creating some excellent pieces of work, one of them being their very own animation.



Year 8

Year 8s have been creating presentations on the History of Computing and exploring the key people involved with the development of technology.

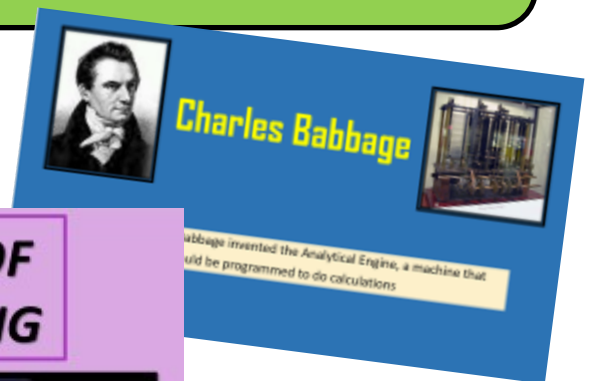

Year 9

The Year 9s have been building and developing their own websites for Teenage Health.



DUKE OF EDINBURGH



Year 10&11 Pupils took part in Canoeing sessions at Chichester Canal during the Autumn term. This was part of their Physical section for the award. They worked on their team work and skills to propel the canoe along the canal.



Duke of Edinburgh Award



Since autumn half terms pupils have been volunteering at Crimsham Farm in Lagness. They have been working in a variety of roles to support the development of the farm and to care for the animals.



LAND BASED STUDIES

The Year 10s have been busy this term learning about how to stay safe whilst gardening, recognising a healthy plant from an unhealthy plant and how to make it healthy. They have also been working on the school garden getting the soil ready for planting the onions and broad beans they have planted indoors in trays and doing lots of weeding and cutting hedges and bushes around the school.



The Year 11 group have been working on their Land Maintenance Unit which has involved them doing lots of outside jobs to make the area look better. They have also created a new seed bed and planted daffodils and tulips.



During this term in PSD, as well as our normal curriculum focus on emotions and body changes, we have had two other focuses in

Mental Health Day

World Mental Health Day took place on 10th October and we focused in: *What is important to us...*

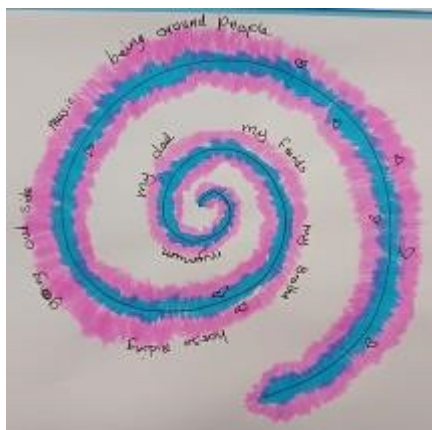

Anti-Bullying Week



Anti-Bullying week took place in November and the focus was Choose Respect.

Pupils were invited to wear odd socks to school to celebrate that we are all unique and we had a focus in lesson about how we can show respect to others.

ART



ART



This term Key Stage 3 we have been working with oil pastels, with Year 8 looking at insects and the Year 9 exploring the vibrant colours of various flora and fauna artists. Year 7 have had a colour explosion with pupils creating collages in the style of Matisse and oil pastel pieces based on Kandinsky.



FOOD TECH



What a busy term this has been! We cannot believe that we are now in December and Christmas is just around the corner. As always we would like to take this opportunity to thank you all for your continued support with our subject and for sending in the funds to buy ingredients for your child this term. We know how much our pupils enjoy their Food Technology lessons and are always very proud of what they have made.

Kind regards, Debbie Wood & Lucy Pratt

Where our food comes from and food in season has been our focus this term. This enables our pupils to think about the impact of where our food travels from and what its source is.

Years 7 & 8 have been making dishes using fruit and vegetables in season and learning about why it is healthier to eat food that is sourced locally. Year 7s developed their preparation skills by working with different fruits and year 8 have been investigating how flour is made and where it comes from. They have enjoyed making a variety of breads and have designed and made their own flavour and style of bread.



Year 9 started their 'food around the world' topic by making British dishes; some very tasty trifles were created. They have also created other British classics such as a cooked breakfast using alternative healthier cooking methods rather than frying and sausages and mash. They are currently investigating Italian foods and recently designed and made their own pizzas.



FOOD TECH

Year 10 have begun their BTEC and ASDAN qualifications and have been very busy preparing and making healthy breakfasts and lunches. At the beginning of the term we focused on different ways to prepare eggs for breakfast. The pupils learnt about consumer awareness through talking about how the eggs we buy in the supermarkets are produced. The pupils thought about the different conditions the hens live in. From our discussions, the pupils felt that free range hen's had a better quality of life and therefore it would be better to buy free range eggs from the supermarkets if they could afford to.



Lastly, Year 11 have been very busy sourcing, preparing and cooking starters, using seasonal fruit to make deserts and main meals in preparation for their final assessment pieces for their BTEC qualification in home cooking in the Spring Term. They have all been working really hard, producing excellent dishes and considering how their dishes are presented. They really enjoyed making their own custard with baked apples and using the food colouring to experiment.



GEOGRAPHY

Year 7 - United Kingdom have been working very hard in their first term here at St Anthony's. They have been learning about the UK. We explored 'where we are in the world'. This included work on locating St Anthony's school, Chichester and understanding why it is a city and looking with the help of Google Earth where we are in the UK.



Year 8 - Peru We enjoyed a trip to Cineworld Chichester to watch 'Paddington in Peru' as part of our current Geography topic. Students loved following the adventures of Paddington down the Amazon river and through the rainforest eventually finding Aunt Lucy and the riches of El Dorado!



Year 9 - Restless Earth

Students have been learning about 'plate tectonics' and how this can lead to volcanoes. They were very excited to carry out a mini volcanic eruption experiment.

SPORTS

Sports at St Anthony's has got off to a brilliant start with all pupils in Secondary taking part in the Intra School Level 1 Boccia and Kurling competitions within their year groups.

From the Level 1 competitions held at school pupils were selected from Year 7 and 8 to represent the school at Inter Level 2 Boccia and Kurling competition.

This was held at Westgate Leisure Centre, the children were brilliant and enjoyed the afternoon playing against other local schools.

Overall we came 3rd in the Boccia event for the West Sussex West area. This is a massive achievement for the children that took part, and we are all very proud of all of the students who took part in both the Boccia and Kurling events.

We also have the PYG competition coming up in May 2025.



Tutor Group news

10A

Not only have 10A been busy in school with their Pathway options and clubs. They have also had a busy time outside of school with lots of fantastic trips, experiences, clubs and helping in their communities. Some of the group attend swimming clubs, horse riding, martial arts, youth clubs, church groups and have lovely days out.

Here are a few snippets of what some of them have done.



Martha has been appointed a choir leader at St Paul's Church, Chichester. She is now one of four senior children and the role is awarded for many reasons, including; helpfulness, kindness, attendance, vocal quality, and being someone that listens.

In Martha's choir, there are 27 children from 11 local schools, and her new role as Choir Leader is a very important part of the choir.

Gabby was really lucky and went to Paris in the Summer Holiday to watch the Olympics. She went with her family and they went up the Eiffel Tower as well as watched some of the Olympics. Here she is in the stadium.



George has had a busy time outside of school as well. He volunteered at a play drop in session through his church group that he attends and spent the morning helping at the play session for younger children.

His artistic talent has been acknowledged again and his Xmas card design was picked to use for the Challengers Youth Xmas card this year.

Challengers★

As well as this, he has done very well at his Martial Arts group. He has now graded to his Orange Belt at Hero's Martial Arts.



10A would like to wish you all a very Happy Christmas and we look forward to telling you more of our achievements next year.

COMMUNITY NEWS



Year 8 students had an exciting time at their kayaking experience at the CYE sailing Centre, Chidham in October.





Christmas Tree kindly donated by the Co-operative Funeralcare in Chichester

- * If your child is absent for illness, appointment or any other reason please contact the school in the morning by telephone - 01243 785965 'or email - schooloffice@st-ants.org
- * Please inform the school office of any contact details changes.
- * Can all uniform be clearly labelled with the child's first and last name.
- * If you pay for your child's school lunch can you please ensure that the balance does not go overdrawn.
- * All school communication is by email and the My Child at School (MCAS) app. If you need any assistance with accessing the app please contact the school office.

Key Dates

Spring Term 2025

Starts: Monday 6th January 2025

Half term: Monday 17th February to Friday 21st February 2025

Ends: Friday 4th April 2025

INSET: Thursday 30th January 2025
Friday 31st January 2025

Summer Term 2025

Starts: Tuesday 22nd April 2025

Half term: Monday 26th May to Friday 30th May 2025

Ends: Tuesday 22nd July 2025

INSET: Friday 13th June 2025